

GENERAL:

1. The objective of this guideline is to provide minimum standards for design and installation of exterior and interior plumbing systems to provide a durable, functional maintainable system which reduces failures over the life of the facility.
2. Design simplicity is emphasized with consideration to maintenance and expansion.
3. Maximum consideration shall be given to water and energy conservation within the limits of life cycle cost effectiveness
4. The health and safety of building occupants shall be the highest priority

DESIGN GUIDELINES:

1. This design guideline establishes the basic requirements for the design of plumbing systems including functions, capacities, plumbing codes, industry standards and system and material limitations.
2. Plumbing system design includes all of the following components and systems:
 - 2.1. Backflow prevention
 - 2.2. Pressure boosting equipment
 - 2.3. Water softeners
 - 2.4. Water heating equipment
 - 2.5. Domestic hot/cold water distribution
 - 2.6. Non-potable hot/cold water distribution
 - 2.7. Sanitary drainage
 - 2.8. Lab waste drainage
 - 2.9. Storm water drainage
 - 2.10. Under slab drainage
 - 2.11. Sewage ejection equipment
3. All design calculations shall be based on the following references
 - 3.1. Potable and non-potable water distribution IPC 2006
 - 3.2. Sanitary waste and vent IPC 2006
 - 3.3. Lab waste and vent IPC 2006
 - 3.4. Service Water Heating ASHRAE Applications
 - 3.5. Compressed Air
 - 3.6. Vacuum
 - 3.7. Natural Gas IFGC 2006
4. Riser diagrams for all systems shall include a fixture unit schedule or summary of design basis for review.
5. Coordination
 - 5.1. Coordination of design is critical to a successful building project. During the design phase of a project, promptly notify architect, structural, civil and electrical engineers of changes which

affect their work. Coordination should include but, is not limited to the following:

5.2. Architect shall

5.2.1. Provide the layout of roof drainage points, restrooms, kitchens locker-room, electric water coolers, janitors' closets etc. to the engineer.

5.2.2. Indicate the ceiling heights where piping must be concealed.

5.2.3. Comply with ADAAG requirements.

5.3. Civil/Structural shall:

5.3.1. Provide the site plan with locations of sanitary, storm and water distribution systems and connection points including piping inverts on sanitary and storm.

5.4. Plumbing engineer shall

5.4.1. Provide information to the electrical engineer of electrical requirements of pumps, water heaters, and electric water coolers.

5.4.2. Shall select all plumbing fixtures and coordinate aesthetics with architect.

5.4.3. Shall relate to the architect and structural engineer chase locations and access door requirements.

6. Backflow Prevention

6.1. All building service shall be provided with back flow preventers at the point of building entry. No metering devices, taps, or other fittings will be located upstream of the backflow preventer. However, if a common supply serves both the domestic water system and the fire protection system, it is preferred the two systems split immediately upon entering the building. Install the backflow preventer for each system at this point.

6.2. As directed by the Project Manager, install two (2) backflow preventers each at 60% capacity.

6.3. Additional backflow preventers are required by IPC code on the following systems:

6.3.1. Non Potable water distribution for use in laboratories

6.3.2. Animal watering systems

6.3.3. Hydronic hot water or chilled water systems

6.3.4. Etc. where needed

6.4. The presence of a backflow preventer will prevent hot water from expanding into the water supply. Provide a properly designed expansion tank to address thermal expansion in hot water plumbing systems.

6.5. All backflow preventers shall be located and configured to allow ready accessibility for maintenance and testing. Minimum clearance is 24" in all directions.

6.6. No backflow preventers will be located more than 4' above the floor level.

6.7. Vertical backflow preventers will not be allowed unless approved by the project manager.

6.8. Pit installations of backflow preventers will not be allowed.

6.9. Drainage from backflow preventers shall be gravity drained to a floor sink of sufficient size to handle flow.

7. Pressure Boosting Equipment

7.1. Designer shall calculate the residual pressure available after the building backflow preventer and the required pressure at the top floor of the facility and evaluate the need for a pressure boosting system.

- 7.2. The minimum residual pressure at the top floor of a building shall be 30 PSI.
- 7.3. Pressure boosting systems shall consist of a minimum duplex pump system complete with adjustable speed drives and a programmable control system.
- 7.4. Designer shall evaluate the need for a storage tank in the system.
- 7.5. If a Booster pump is required for any part of the building system, then it shall be used for the entire building system.

8. Water softeners

- 8.1. A water softener is required for all domestic or non-potable water heaters
- 8.2. Other systems such as water service for Autoclaves may also benefit from using soft water
- 8.3. Size water softener capacity based on local water chemistry analysis provided by the utility or the Project Manager.
- 8.4. Water softeners shall be located in a room easily accessible by a pallet jack with a pallet of salt. Space shall be provided for at least one pallet of salt next to the brine tank. Large systems may require additional space. Under NO circumstances shall salt delivery and handling require the use of stairs.

9. Water Heating Equipment

- 9.1. Water heater shall be a steam fired, semi-instantaneous, vertical storage heater or steam fired instantaneous as directed by the Project Manager.
- 9.2. Where campus steam is not available, consultant may use natural gas fired heaters. Gas water heaters shall be a high efficiency, powered vent design with both PVC combustion and vent piping. Electric water heaters will only be allowed if approved by Project Manager.
- 9.3. Water heater shall be capable of entering a mechanical room through a standard 3'-0" x 6'-8" door. Maximum capacity of this size tank will be about 200 gallons.
- 9.4. After the engineer calculates the initial storage capacity and recovery, the engineer shall provide an equivalent overall system based on a smaller storage tank and larger recovery coil.
- 9.5. Multiple tanks are acceptable and may be required to meet demand.
- 9.6. Design temperature rise shall be 40F -140F.

10. All Piping Systems

- 10.1. No plumbing piping shall run through electrical rooms or elevator equipment rooms. This includes hot, cold, waste, vent, storm, piping systems.
- 10.2. There will be no floor drains in electrical rooms.
- 10.3. Relate to the structural engineer specific requirements for pipe routing and equipment supports.
- 10.4. Structural members shall not be modified to accommodate piping.

11. Domestic hot/cold water distribution

- 11.1. Follow generally accepted practices found in IPC, ASHRAE, ASPE resources.
- 11.2. Provide adequate shutoff zoning valves for maintenance. Typically at each floor, each branch or each restroom. DO NOT locate them in front of the restroom door.
- 11.3. Provide an accessible shutoff valve for each exterior wall hydrant

- 11.4. Provide a minimum of one exterior wall hydrant on each exterior wall and at least one wall hydrant every 100 lineal feet of exterior wall.

12. Non-potable hot/cold water distribution

- 12.1. Follow generally accepted practices found in IPC, ASHRAE, ASPE resources.
- 12.2. Provide adequate shutoff zoning valves for maintenance, typically at each floor and/or each branch.
- 12.3. Provide shutoff valves for each laboratory, but not in front of the lab door.
- 12.4. Label non-potable water at each outlet and at each sink.

13. Hot Water Recirculation

- 13.1. Hot water piping systems layout shall minimize the amount of recirculation piping required. A majority of heat loss in a hot water system comes from the re-circulation piping.
- 13.2. Use ASHRAE Applications, Chapter 49, Figure 2, as guidelines for system layout.
- 13.3. Each return branch shall have a calibrated balance valve.
- 13.4. Flow from each branch shall be as follows:
 - 13.4.1. .5 gpm for a ¾" or 1" riser
 - 13.4.2. 1 gpm for 1 ¼" and 1 ½" risers
 - 13.4.3. 2 gpm for risers 2" and larger.
- 13.5. Pipe flow velocity in return lines shall not exceed 2 fps.
- 13.6. Hot water recirculation pumps shall be close coupled, with a non-metal impeller. A main circuit setter shall be located on the discharge side of the pump.
- 13.7. Pump start-stop shall be connected to building automation system (i.e. Metasys for MU, Honeywell for UMKC, etc.) for scheduling.
- 13.8. Storage temperature shall be 130F. Delivery temperature shall be 120F
- 13.9. Department equipment requiring higher temperatures, a separate booster heater shall be provided with the equipment.

14. Sanitary drainage

- 14.1. Follow generally accepted practices found in IPC, ASPE resources.
- 14.2. In accordance with the IPC, all drainage systems located above the exterior sanitary sewer flowline elevations shall be GRAVITY flow.
- 14.3. Where a portion of the building drainage system is below the exterior sanitary sewer flowline elevations, the flow from that portion shall flow to a tightly covered and vented sump. A sump pump shall lift and discharge the effluent into the building gravity drainage system.
- 14.4. The connection point for pumped flow SHALL BE into the nearest manhole. Pumped flow shall not be connected into the building gravity flow unless approved by the Project Manager.
- 14.5. All sump pump stations shall be duplex.
 - 14.5.1. Exception: A simplex pump is acceptable for non- critical, clean water locations such as a condensate pump pit.
- 14.6. If the Project Manager approves tying the pumped flow into the gravity drain, the building drain shall be sized to accept full pump flow to avoid backing up into the gravity system.

One (1) gpm of sump pump flow will count as 2 Fixture Units for drainage calculation purposes.

14.6.1. While the basement fixture determines the sump pump sizing, the actual pump flow and head will determine the Fixture Units used for the final building drain sizing calculation.

15. Lab waste drainage

15.1. Follow generally accepted practices found in IPC, ASPE resources.

15.2. Provide serviceable (easily removable) P-traps at all lab sinks.

16. Storm water drainage

16.1. Follow generally accepted practices found in IPC, ASPE resources.

16.2. Roof Drainage

16.2.1. Architectural considerations typically dictate roof design and thus the roof drainage system. In as much as it is possible, the intent of these guidelines should be used in the design of the roof drainage system.

16.2.2. Interior storm drainage piping is required unless another method is approved by the Project Manager. Exterior downspouts are not acceptable.

16.2.3. Where secondary (emergency) drains are required, preference shall be given to scuppers first and a secondary piping system second.

16.2.4. Secondary (emergency) roof drains shall not be located in the same sump as the primary roof drain.

16.2.5. Secondary (emergency) drains, both scuppers and interior piped systems shall discharge their drainage in a visible location THAT DOES NOT CAUSE ADDITIONAL PROBLEMS such as on water on a sidewalk that freezes in the winter.

16.2.6. Roof drainage system shall NOT connect to the foundation or underslab drainage system.

16.2.7. The base of the roof drain and all horizontal roof drain lines to the main vertical stack shall be insulated.

17. Foundation drainage

17.1. All below grade buildings shall have an exterior footing drainage system.

17.2. Drainage system shall be gravity where possible.

17.3. Where the footing drains are above the storm water flowline, bring the footing drainage into the basement of the building to a clean water sump pump system. This system shall discharge to the storm water sewer through a dedicated piping system.

18. Under slab drainage

18.1. Where soil testing indicates the presence of underground water and the need for an under slab drainage system, the systems shall drain by gravity to the storm sewer where possible.

18.2. Where the under slab drains are above the storm water flowline, bring the drainage to a clean water sump pump system. This system shall discharge to the storm water sewer

through a dedicated piping system.

- 18.3. The under floor system and the foundation drain may be brought to a common sump pump but, collection piping shall not be combined. Each system should have a separate inlet to the sump.

19. Elevator pit interior drainage

- 19.1. Where required by code, elevator pits shall have a sump and an oil minder pump.
19.2. Pump discharge shall be routed to a floor drain connected to the sanitary waste system in the nearest mechanical room.

20. Elevator pit exterior drainage.

- 20.1. Where soil testing indicates the presence of underground water, and the need for under slab drainage, the bottom of the elevator pit will typically be 6 to 8 ft lower than the adjacent under slab drainage and therefore require a separate drainage system.
20.2. Gravity drainage is preferred where possible. Where the elevator drains are above the storm water flowline, bring the elevator drainage to a separate sump pump to a clean water sump pump system. This system shall discharge to the storm water sewer through a dedicated piping system.
20.3. DO NOT combine the higher underslab drainage system with the lower elevator pit drainage system. See Drawing P-??

21. Sump Pumps

- 21.1. All pumps shall be submersible type
21.2. Elevator sump pumps shall be oil minder type pumps
21.3. Sump Pumps for clean water waste (e.g. mechanical room floor drains, underslab drainage) shall be submersible effluent sump pumps
21.4. Sump pumps for sanitary waste shall be grinder type pumps.

22. Sump Pump Controls

- 22.1. MU will provide a control panel for contractor installation. See detail X.X.
22.2. Each pump system requires the following electrical service to the control panel:
22.2.1. Separate power for each sump pump. Electrical service to be determined.
22.2.2. 120 volt control power circuit
22.2.3. Alarm System
22.3. All float switches shall be mounted above the sump.
22.4. Floats shall be stainless steel.

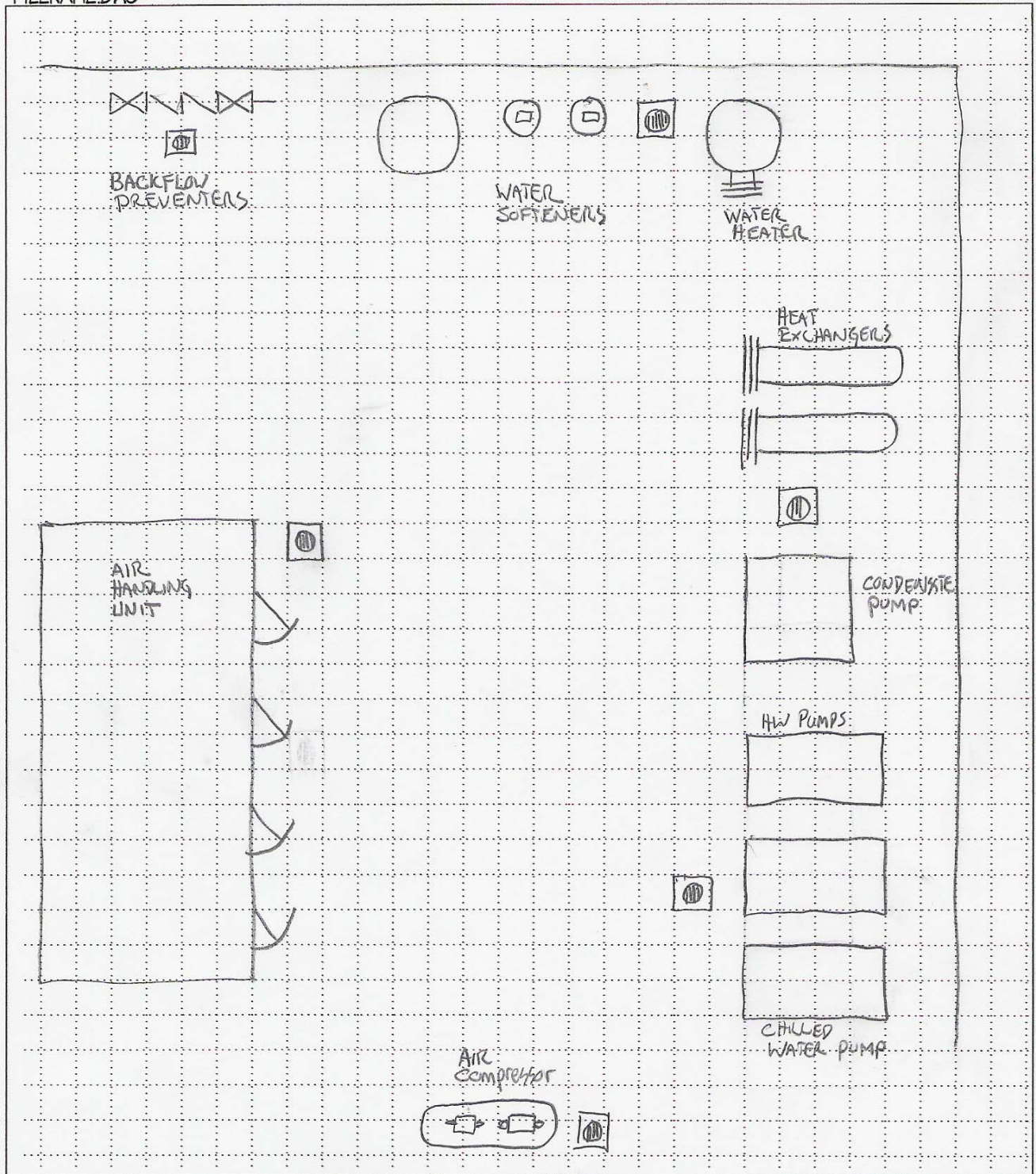

DATE: 1/5/2008
 ▲
 ▲
 ▲
 ▲
 DWN BY: LS
 CKD BY: ls

MECHANICAL ROOM FLOOR DRAIN
 TYPICAL LOCATIONS
 maintenance details

 MAINTENANCE
 CAMPUS FACILITIES
 UNIVERSITY OF MISSOURI-COLUMBIA

PROJECT NUMBER
 SHEET
1 of 50

FILENAME.DWG

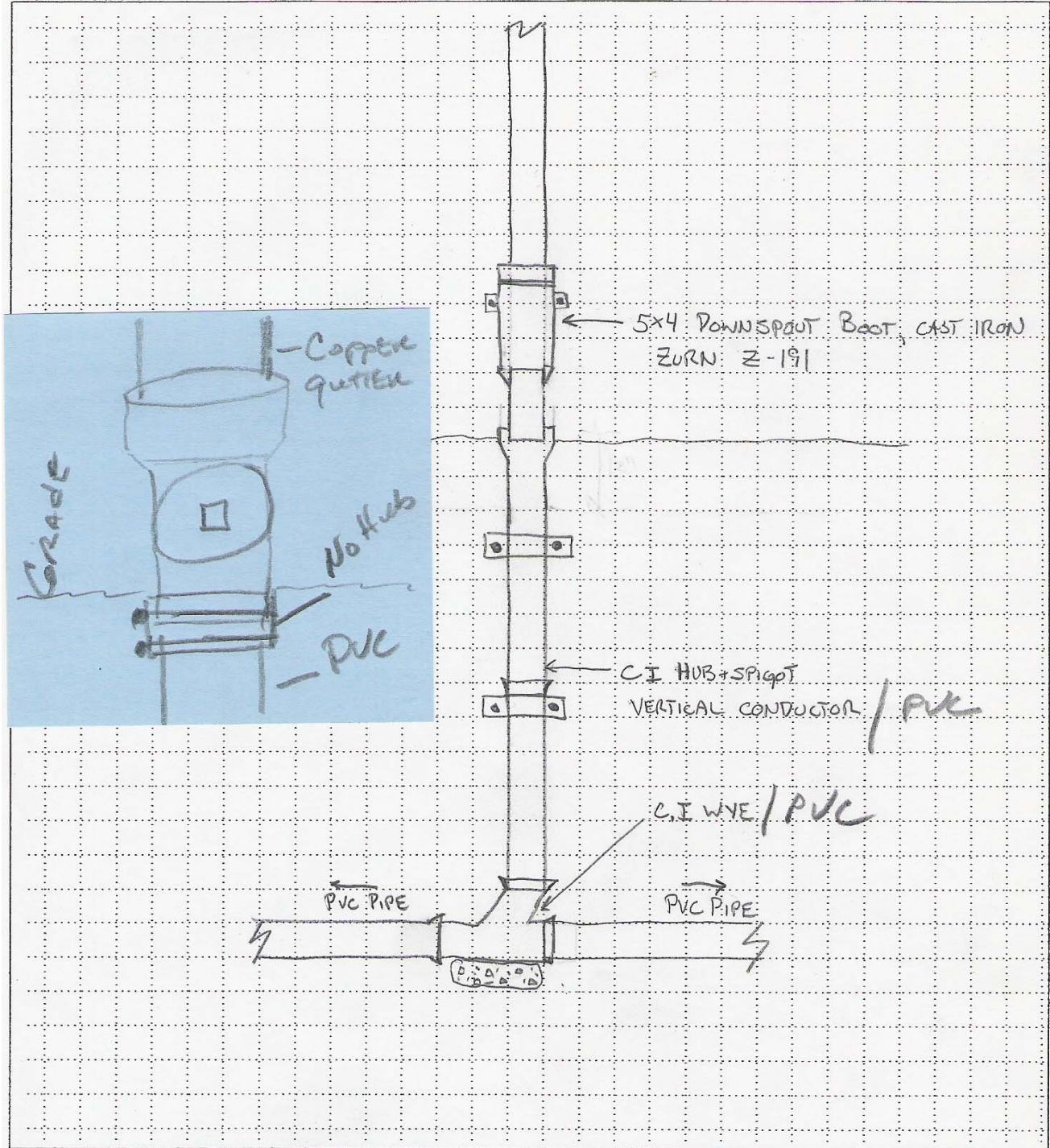

DATE: 1/5/2008 ▲ ▲ ▲	RAIN LEADER DETAIL maintenance details	PROJECT NUMBER SHEET
DWN BY: LS CKD BY: ls	 MAINTENANCE CAMPUS FACILITIES UNIVERSITY OF MISSOURI-COLUMBIA	1 of 50

FILENAME.DWG

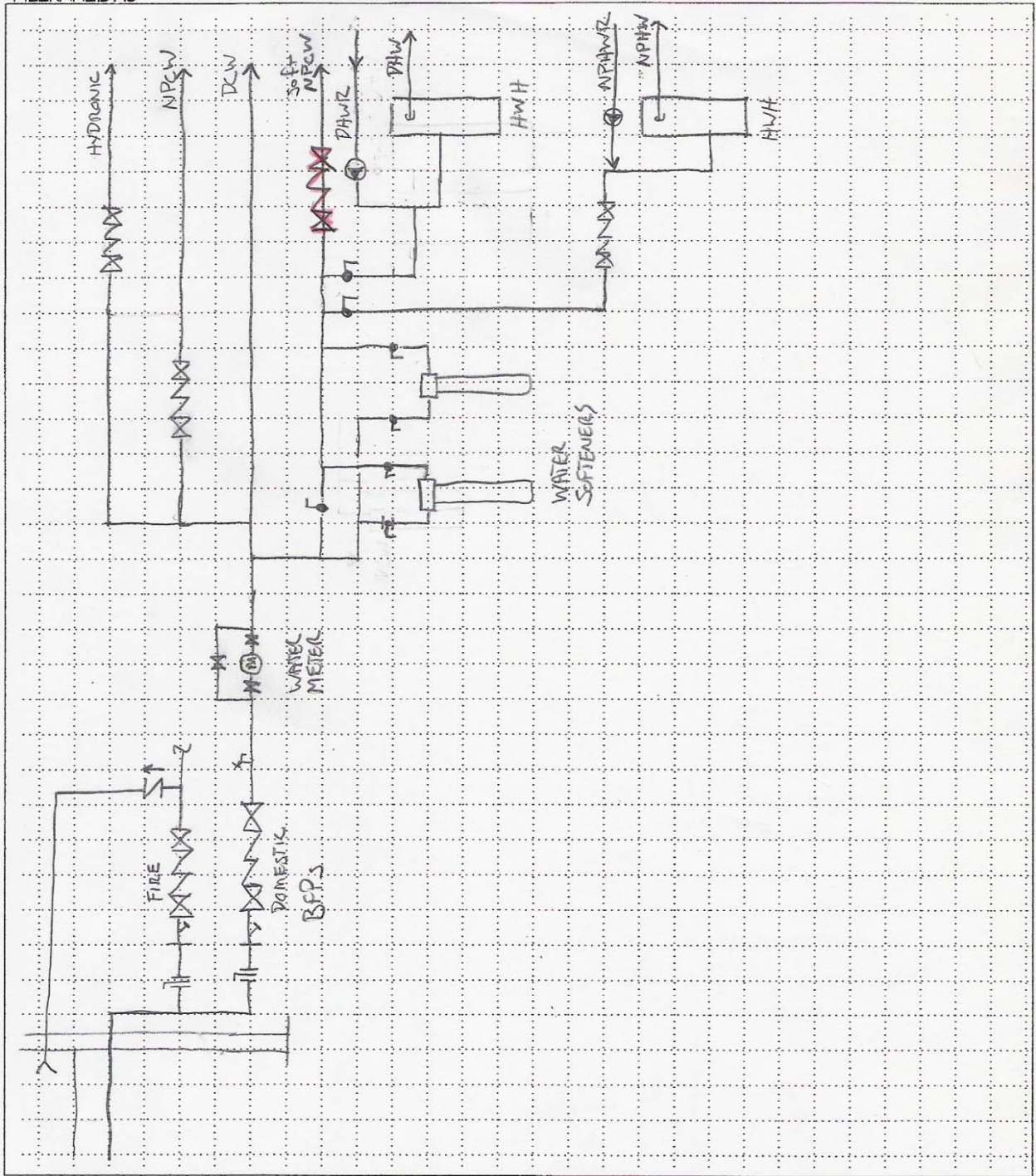

DATE: 1/5/2008
 ▲
 ▲
 ▲
 ▲
 DWN BY: LS
 CKD BY: ls

PLUMBING WATER Supply DIAGRAM
 maintenance details

 MAINTENANCE
 CAMPUS FACILITIES
 UNIVERSITY OF MISSOURI-COLUMBIA

PROJECT NUMBER
 SHEET
 1 of 50

xxxxxxxxx.dwg

THE FOLLOWING
 EQUIPMENT REQUIRES
 A FLOOR DRAIN:

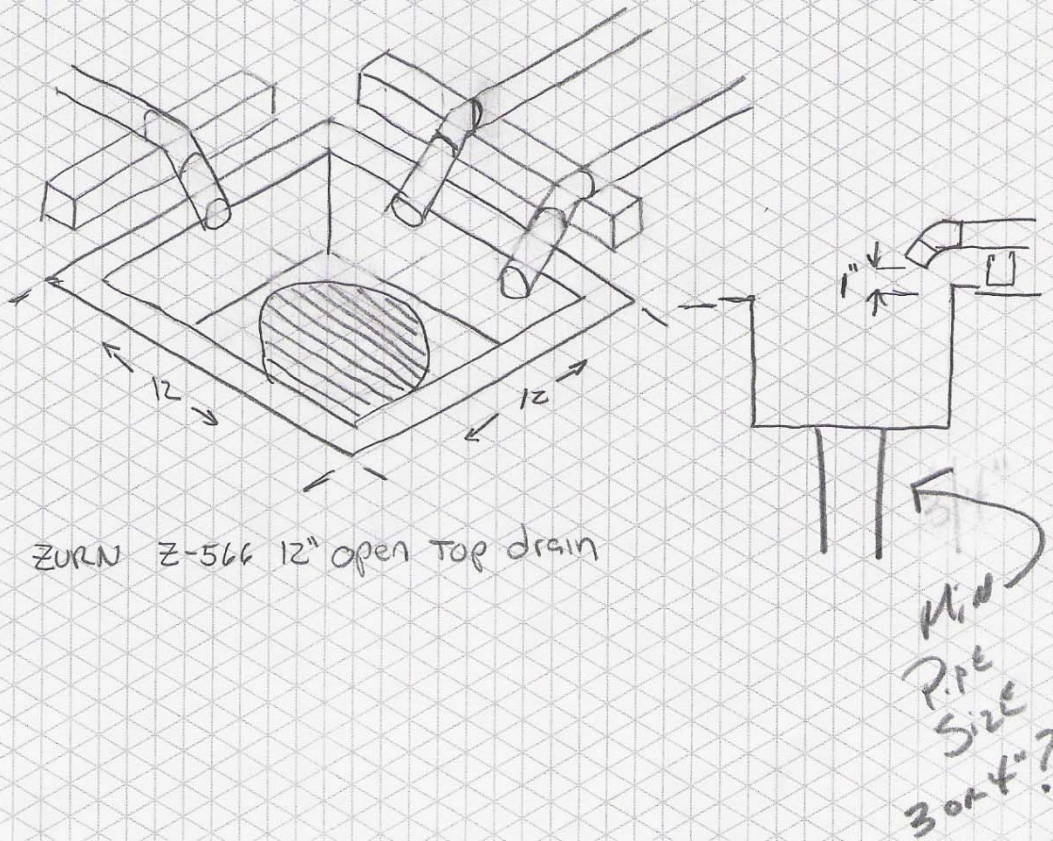
- BACKFLOW PREVENTERS
- WATER SOFTENERS
- WATER HEATERS
- HEAT EXCHANGERS
- CONDENSATE PUMPS



DATE:	MECHANICAL ROOM FLOOR DRAIN	PROJECT NUMBER
▲ ▲ ▲		SHEET
DWN BY: CKD BY:		 MAINTENANCE CAMPUS FACILITIES UNIVERSITY OF MISSOURI-COLUMBIA